

# A150 Clip

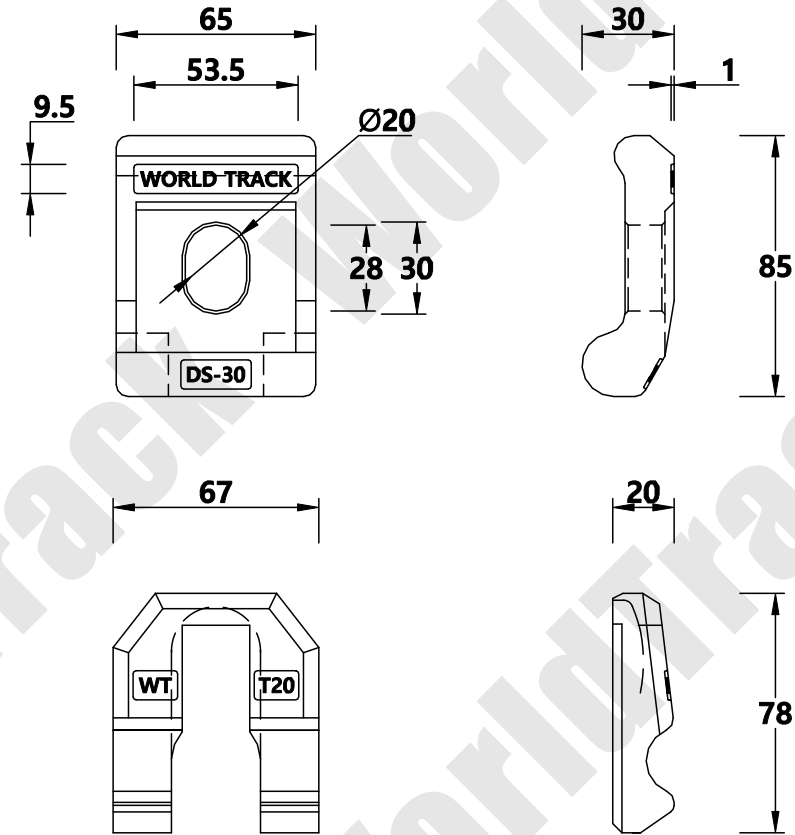
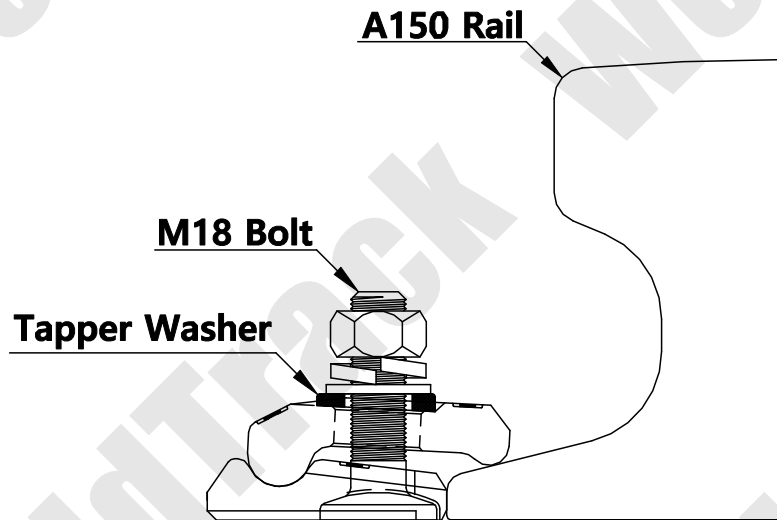

**WT WORLD TRACK**

THE TECHNICAL DATA CONTAINED IN THIS DRAWING IS PROPERTY OF WORLD TRACK LIMITED AND IS SUBJECT TO COPYRIGHT

**WORLD TRACK**

TEL : 82)2-2605-2380  
 FAX : 82)2-2601-2382  
<http://www.world-track.net>  
 E-Mail: world-track@hanmail.net

Clip Designation	150/DS-PN-T2/3020	Drawing Number	C/DS-330	
Clip Type	Double Single	Checked By	Lee Se Wan	
Fixing Method	Bolted Clip	Date	2016 / 01 / 21	
Accessory List		Scale	1 / 1	A4
Clip(상), Clip(하) / Bolt / Nut Spring Washer / Tapper Washer / Washer		<b>ANGLE PROJECTION</b> 